

DHK050-5-200A Series-High Current Slip Ring

DHK050-5-200A Description:

DHK050-5-200A series high current through bore slip ring outer diameter 50mm ,5 electrical terminal and transmit 200A high current ,fully enclosed structure, high protection level and easy to install

DHK050-5-200A Customized Options:

- ◆Rated current, voltage
- ◆Rated speed
- ◆Operating temperature
- ◆Number of channels
- ◆Shell material and color
- ◆Dimensions
- ◆Special wire
- ◆Wire outlet direction
- ◆Wire length
- ◆Terminal type
- ◆Protection grade

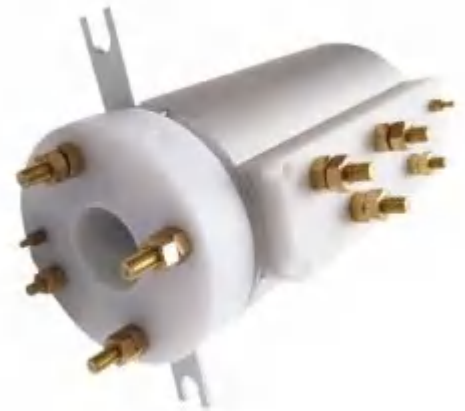

Typical Application:

Wind power generation-For large wind turbines, it may be necessary to handle very high currents, so 1000A-class slip rings are ideal

Heavy construction machinery-Heavy machinery such as excavators and cranes often require 360-degree continuous rotation of their slewing platforms or superstructures

Port loading and unloading equipment-Gantry cranes, container cranes and other equipment used in ports also rely on high-current slip rings to ensure uninterrupted transmission of power and signals when the spreader rotates

Metallurgical industry-Various rotary kilns in metallurgical plants, such as arc furnaces, also need to use high-current slip rings to transmit power to rotating parts for operations such as metal smelting.

DHK050-5-200A Standard Drawing :

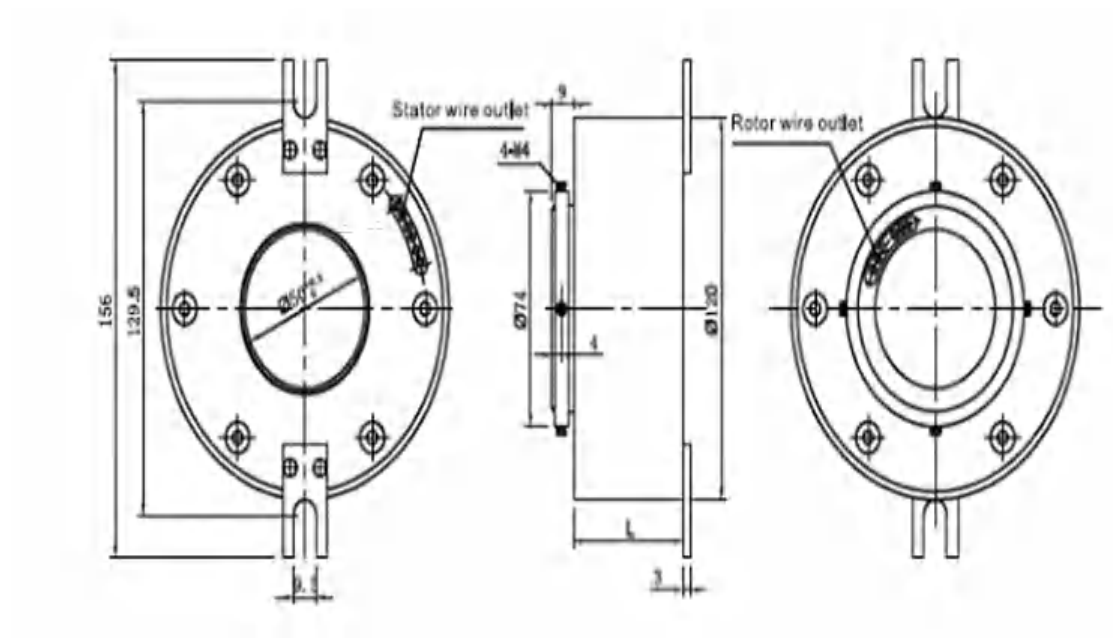

DHS050-5-200A Technical Parameters:

Product Grade Table			
Product grade	Working speed	Working life	
General	0 ~ 200 rpm	20 million revolutions	
Industrial	300 ~ 1000rpm	60 million revolutions	
Technical Parameters			
Electrical technical		Mechanical technical	
Parameters	Value	Parameters	Value
Number of rings	5 Ring or Custom	Working temperature	-40°C ~ +65°C
Rated current	200A	Working humidity	< 70%
Rated voltage	0 ~ 440VAC/VDC	Protection level	IP54
Insulation resistance	≥1000MΩ@500VDC	Shell material	Aluminum Alloy
Insulation strength	1500VAC@50Hz,60s,2mA	Electrical contact material	Precious metals
Dynamic resistance change value	< 10mΩ	Lead specification	Colored Teflon
Working speed	0-600rpm	Lead length	500mm+20mm